



HYPERION TECH 3.0



STEPS INTO THE FUTURE





HYPERION TECH 3.0

Welcome to the future of car washing

HYPERION TECH 3.0, THE FIRST ROLLOVER UNIT OF THE 3.0 RANGE BY CECCATO.
Flexible, ecological, extremely fast (car washing in less than 3 minutes), in a word: smart.

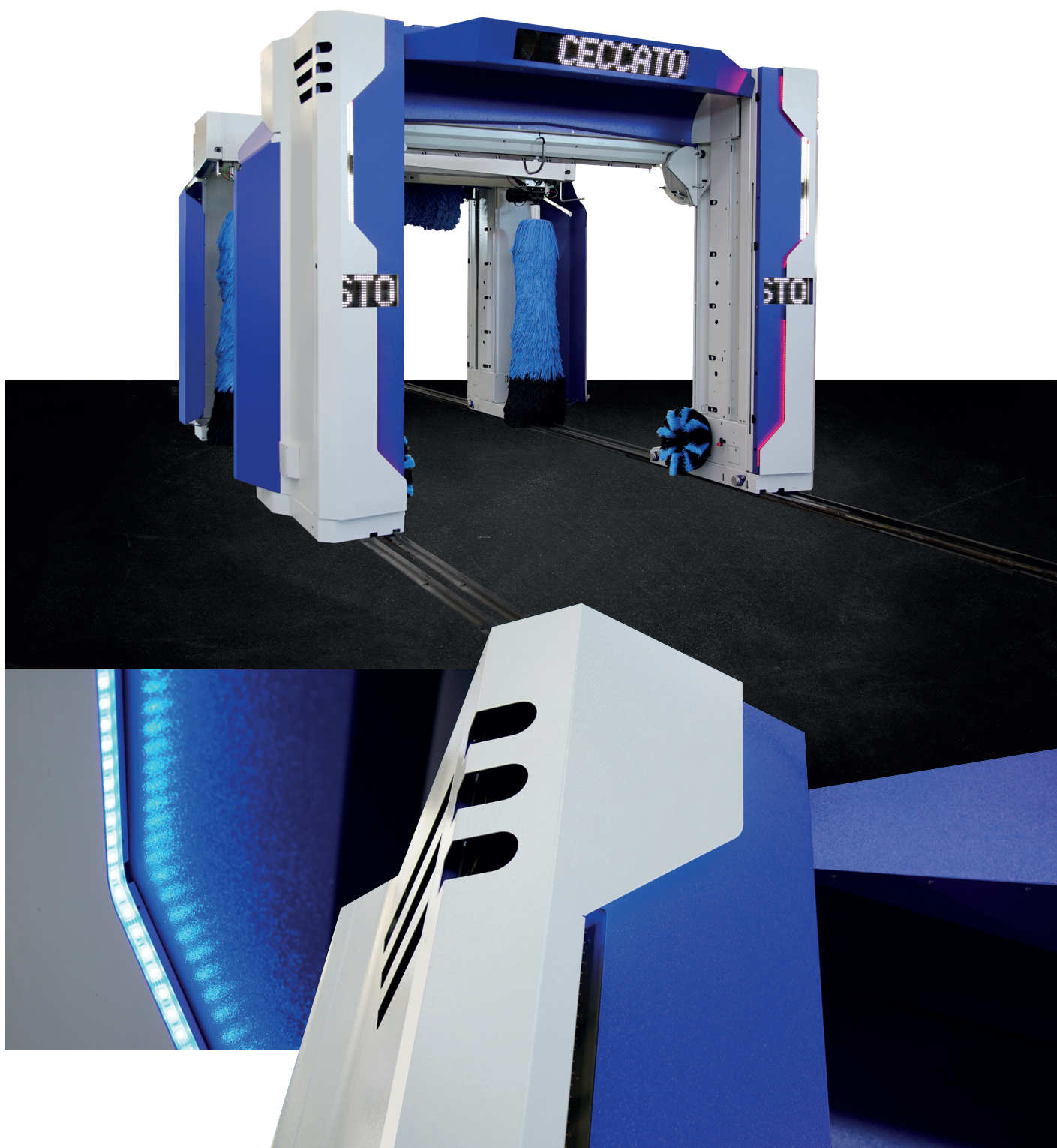



FLEXIBLE, ECOLOGICAL, SIMPLE

Hyperion Tech 3.0: productivity squared



**SIMPLE
INTERFACE**



**CHIP CARD OR
KEY ACTIVATION**



**APP FOR REMOTE
MANAGEMENT**



**TOUCH
SCREEN**



TOUCH SCREEN

App for remote management

All system parameters are easy to access and intuitive. The system is enabled for two-way communication by remote with any device (phone, tablet, PC).



WASHING CYCLES

Unique programming and definition of washing cycles

This function not only improves the speed of troubleshooting, but also allows the immediate and identical reproduction of programming on another equivalent system, or on the "TEST" plc. This function is particularly useful in cases where multiple systems are simultaneously managed, insofar as it is possible to obtain equal washing results and consumption by simply inserting a code.



WASH PERFORMANCE



RETURN ON INVESTMENT STARTING FROM

650 washes/month up to 2,000 washes/month



NEW LUMINOUS DISPLAY AND RGB LEDs

It's important to like what you see

HYPERION TECH 3.0 has been designed to attract attention. Thanks to a large, high-visibility LED display located on the side and top walls, it clearly and intuitively communicates with the end user. Advertisements can also be shown on these displays, or else information inherent to the washing cycle and self-service activation.

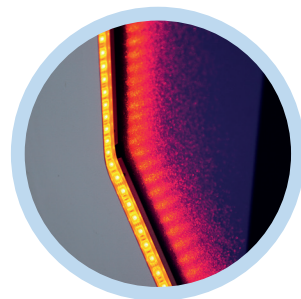
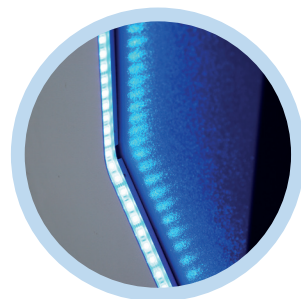
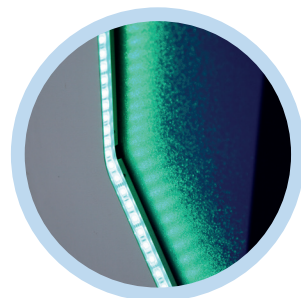
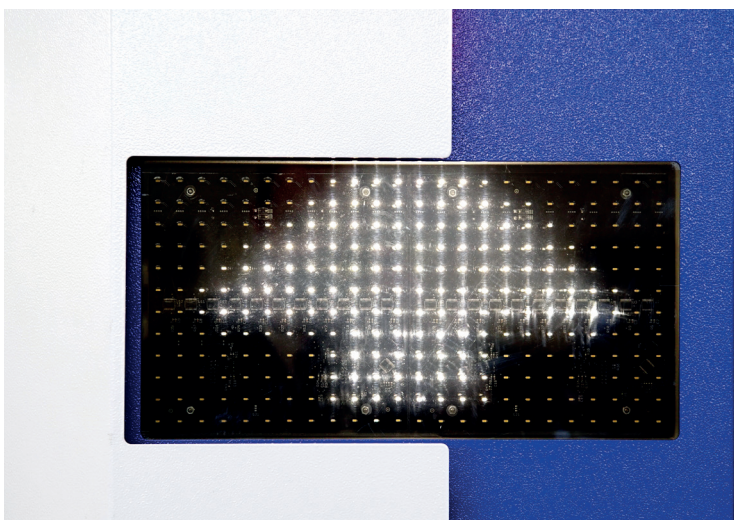

RGB LEDs

A series of RGB LEDs, which continuously change colour, offer the system a high visual impact.



PREMIUM VERSION

Moving profile

This version is characterised by the action of the horizontal device that performs the pre-washing, washing and drying actions, perfectly and safely respecting the profile of vehicles. The sprayed water and air flows are directed by an asymmetrical deflector to follow the shape of the vehicle as accurately as possible. The possibility to programme and optimise the high pressure, emollient and drying cycles, guarantees a sure reduction in washing times and maximum cleanliness.





ADAPTIVE SHAPE FIT SYSTEM

Smart inclination

Thanks to a sophisticated software system, HYPERION TECH 3.0, unique in the market for double rollover units, is able to independently decide whether to tilt the vertical brushes over the rear of the vehicle and by how much, based on the inclination of the back window. HYPERION TECH 3.0, the smart machine.

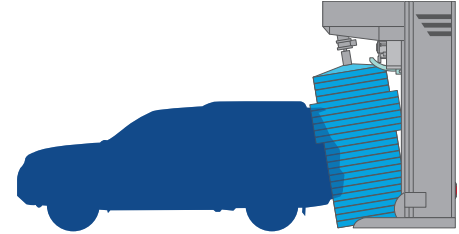



SELF-REGULATING DOSING PUMPS

Self-regulating based on the system speed and outdoor temperature

Using a sophisticated algorithm, the system is able to increase the amount of product dispensed as the system speed increases, and likewise reduce the amount of product when the system slows down, thus guaranteeing more even distribution across the surfaces to be cleaned, in addition to savings on chemical products. The pump management algorithm also considers the operating temperature.



WHEEL MASTER

Power and lightness

Wheel Master is the system dedicated to washing the wheels, side panels and all lower parts of vehicles. Enriched by a pair or trio of high-pressure nozzles (depending on the selected configuration), in an ideal balance of power and pressure, Wheel Master ensures deep cleaning even in hard-to-reach places.

Made completely in stainless steel, it supports various combinations of use: shampoo dispensing only, high pressure only, brushing only or a combination. Moreover, regardless of the specific products used, this technology allows a long-lasting action able to guarantee efficient cleaning.





HIGH-PRESSURE PUMP RACK

Added value

The set of components comprising the pumping system are pre-assembled by the company with the aim of occupying as little space as possible. This translates into significantly reduced installation times and the resizing of the area dedicated to the washing system.



TSD TURBO SIDE DRYER STANDARD

Top quality drying

TSD: the solution to eliminate “dead spots” during the typical stages of drying; the regular intersection of vertical and horizontal currents tends to create a vortex making drying less consistent. TSD positions itself between the two currents, eliminating the vortex for impeccable vehicle drying. Lateral drying runs up the full height of the vehicle and has been further improved, featuring increased motor power and noticeably quieter performance.

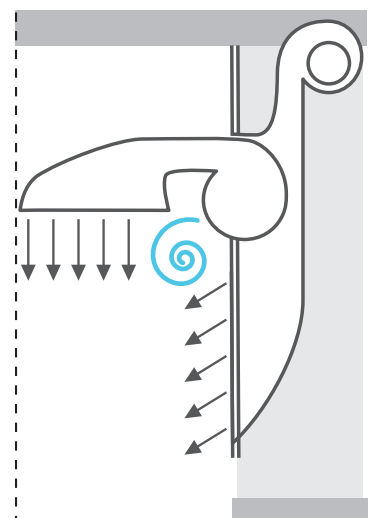

Air flows without conveyor

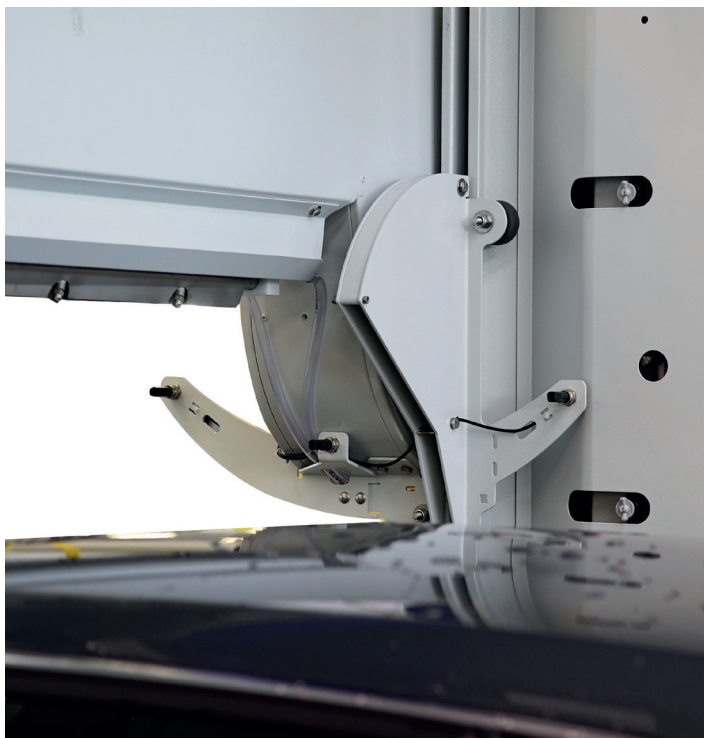

Vertical full-height drying nozzle

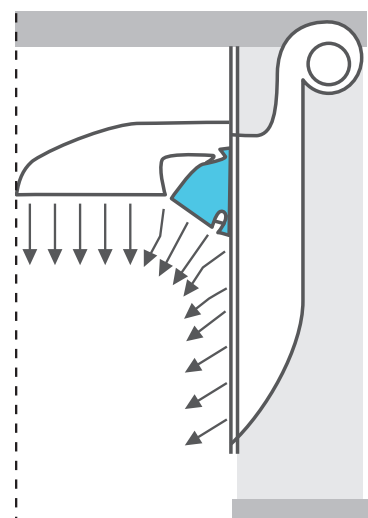

Air flows with conveyor





PROFILE CONTROL TECH

Sensitive intelligence

The system, already broadly adopted across all Ceccato systems, allows the vehicle profile to be interpreted in detail, eliminating the "step" movements of the horizontal brush. Constant pressure on the car body, thanks to a fluid movement, guarantees better and faster cleaning. On HYPERION TECH 3.0 the system has also been implemented on the vertical brushes in order to avoid calibrations and jerking during this step. Thanks to the use of inverters for brush control, a delicate touch is also guaranteed at high speed.

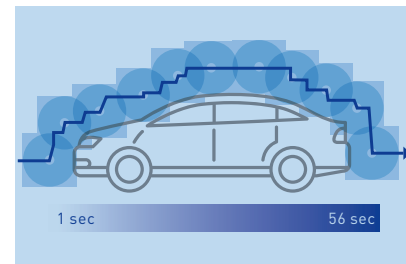

**PROFILE CONTROL BY STEP
WITH OSCILLATING DEEP CLEAN**

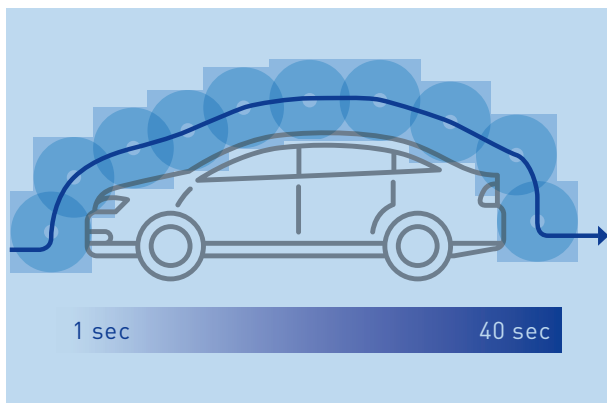

**"VECTOR PLUS" CONTINUOUS PROFILE CONTROL
WITH CONSTANT DEEP CLEAN**

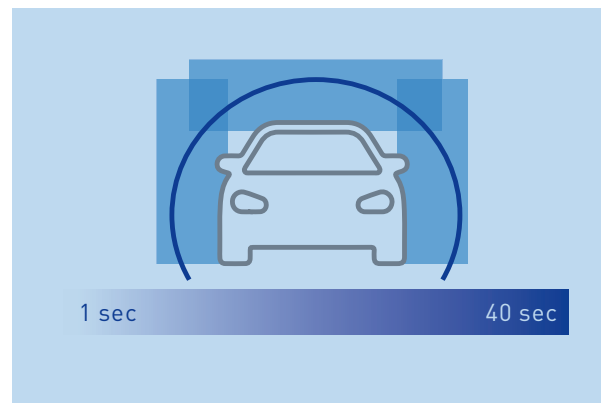

**"VECTOR PLUS" CONTINUOUS PROFILE CONTROL
WITH CONSTANT DEEP CLEAN**



ENERGY EFFICIENT INVERTERS

Huge advantages

HYPERION TECH 3.0 is the only system on the market able to recover the energy produced by the electric motors during the braking stage. The electrical energy produced by the braking motor is stored on the buffers of the inverters and released during the acceleration phase. This allows important energy savings of at least 10% with respect to similar systems not equipped with this technology. It also stabilises the power line, which is otherwise often the cause of faults to electronic parts.





OPTIONAL



LIGHT CURTAINS

No more obstacles

Thanks to two banners located on the front doors of the drying rolover unit, the system memorises the shape of the vehicle in millimetric detail during the first cycle, including any obstacles (luggage racks, skiboxes, bike racks, etc...) and is therefore able to manage them in total safety. Antennas and sirens will no longer be a problem, and operators will no longer need to manage these obstacles.



EMOLLIENT

High-pressure water flows

During the pre-washing stage, the software allows management of the dispensing of one or two emollients, and for distribution to be varied across the surfaces of the vehicle. Likewise, medium or high-pressure water flows can be programmed and customised. The accurate management of dispensing intensifies washing in the most dirty and hard-to-reach areas.



ASBC

Adaptive Side Brush Control

The system recognises the presence of taller vehicles, and instead of blocking the inclination of the brushes, activates ASBC, a device that keeps the brushes floating to ensure the efficient washing of the highest part of SUV and Van sides, increasing the washed surface by 30%.



OPTIONAL



POLISH PROGRAMME

Shine and profitability for your programme

Polishing is possible using an atomised or foam product. The atomised polish is dispensed together with the air, creating a soft cloud that completely envelops the vehicle. This method is particularly suited to systems installed in closed environments. The foam polish, very resistant to wind, sun and weather conditions in general, doesn't require a pre-washing stage.

The foam can in fact be dispensed during the first brushing cycle, thus shortening polishing times to two (maximum three) strokes as opposed to the standard four.

Accuracy and time optimisation combined.



COLOURFUL WATERFALL

A touch of sophistication

A waterfall of foam illuminated by LED lights creates a colourful effect on the vehicle, covering it with thick foam and enhancing the lubricating action of the brushes and/or interacting with the emollient for deeper, and above all, spectacular cleaning.

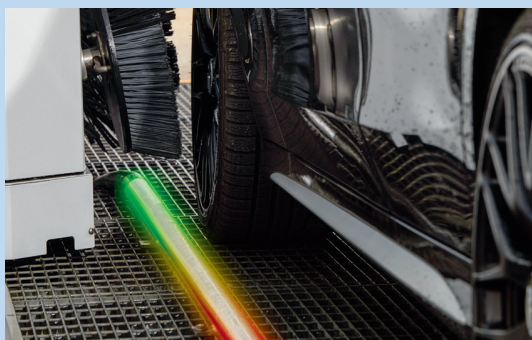

LED WHEEL GUIDES

Enter the scene with some extra help

Thanks to stainless steel tubes containing multicoloured LEDs with a range of available effects, positioning the vehicle will be even easier, with a high-impact scenic effect.



TECHNICAL DATA

System dimensions

	HYPERION TECH 3.0 STANDARD		HYPERION TECH 3.0 LARGE		
	mod. 240	mod. 260	mod. 240	mod. 260	mod. 295
System width	4000 (including splash guards)		4300 (including splash guards)		
System length	max 2830		max 2830		
System height	3215	3430	3215	3430	3780
Max. passing width	2400		2700		
Max. vehicle width	2100		2400		
Max. vehicle height	2350	2600	2350	2600	2950

Drive through dimensions

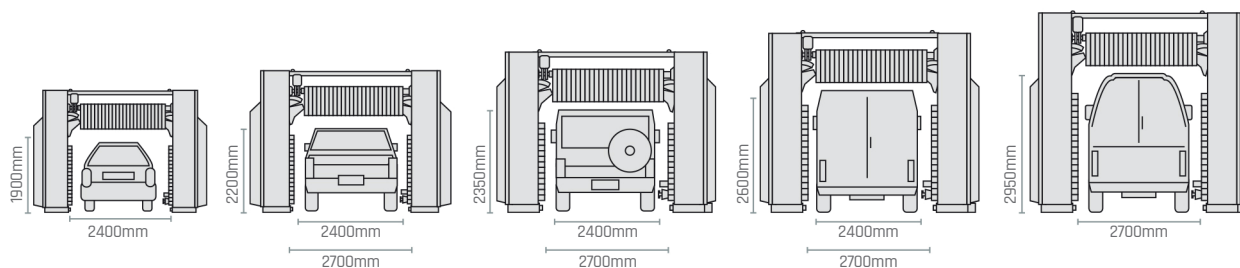

Available colours

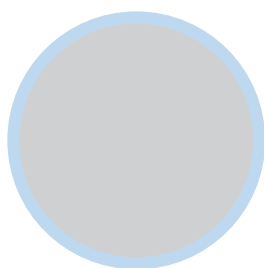

LIGHT GREY
RAL: 7035

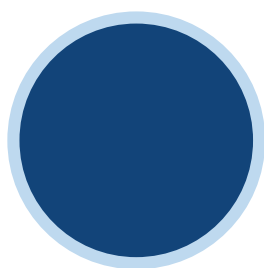

ULTRAMARINE BLUE
RAL: 5002

In addition to our colour range available on order, it is possible to personalise Hyperion Tech 3.0 with your own colours (selected from the RAL colour chart)



Ceccato Spa
Via dell'Innovazione 5/7
36040 Grisignano di Zocco
Vicenza - Italy

T. +39 0444 708411
F. +39 0444 708405
info@ceccato.it
www.ceccato.it

